

ADS1 DynaFill™ - Adhesive Delivery System

The ADS1 DynaFill™ automatically replenishes adhesive to the desired level in hot melt equipment. A low level indicator sends a signal to the DynaFill™ that adhesive is needed. The DynaFill™ then activates a venturi that draws the adhesive into a positive pressure air stream and deposits it into the hot melt unit.

ADS1 DynaFill™

- On-Demand adhesive replenishment saves operator time and prevents thermal shock to adhesive.
- Automatically feeds units up to 20 feet vertically and 100 feet horizontally.
- Adhesive wand can be used in various containers for efficient adhesive delivery.
- Alarm indicator lights alert fill/no fill status.
- Stainless steel construction for corrosion resistance.
- Transparent container allows for adhesive level visualization.

Flexibility

The DynaFill™ is compatible with most ITW Dynatec and/or competitive hot melt machine configurations.

Energy Efficiency

Low air consumption of only 20 SCFM at 50 psi during adhesive feeding.

Reliability

Adhesive supply levels are automatically maintained with a sealed system that virtually eliminates system contamination.



ITW Dynatec - ADS1 DynaFill™
Shown with optional caster base.

The Dynatec Difference...

Flexibility

The DynaFill™ has been designed to give the customer more flexibility in manufacturing operations. The adhesive wand can be placed in most adhesive containers such as: boxes, plastic containers, and bulk manufacturer's shipping containers.

ADS1 DynaFill™ - Adhesive Delivery System

System	ADS1 DynaFill™
Adhesive Size	Up to 1/2" Slat
Adhesive Capacity	55 gal or 114 kg (250 lbs)
Adhesive Transfer Rate*	340kg (750lbs)/hour
Adhesive Transfer Length	Up to 6m (20ft) vertically and 30.5m (100ft) horizontally
Operating Air	Minimum: 3.5 bar (.35Mpa or 50psi) Maximum: 5.5 bar (.55MPa or 80psi)
Air Consumption	566Liters/min (20scfm) when feeding
Air Connection	1" supply to 1/2" tube connection at unit

*Transfer rates are dependant upon adhesive type.

Dimensions	Wand	Lid Assembly*
Height (H)	123cm (48in)	48cm (19in)
Depth (D)	15cm (6in)	27cm (10.75in)
Width (W)	15cm (6in)	27cm (10.75in)

* Lid sizes vary depending on type of adhesive supply unit being fed.

Optional Features
<ul style="list-style-type: none"> • Caster base for mobility • Capabilities for audible alarm or secondary stack light

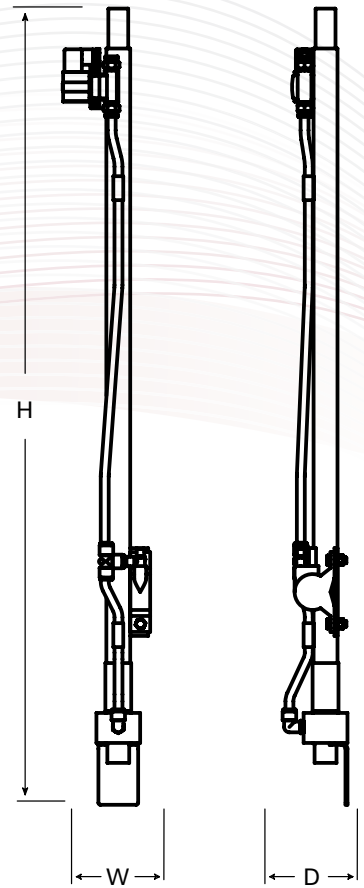
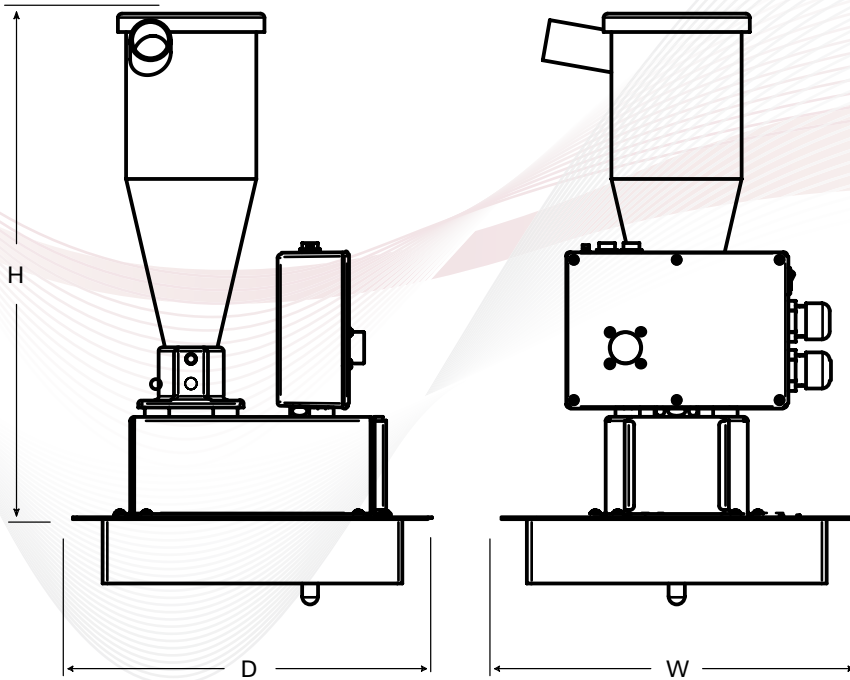

© 2008 ITW Dynatec
ITW Dynatec reserves the right to discontinue or change specifications, designs, materials and equipment without notice or obligation.

ASIA
ITW Dynatec Hong Kong
Unit A-B, 11/FI., Leahander
Centre 28
Wang Wo Tsai Street
Tsuen Wan NT Hong Kong

AMERICAS
ITW Dynatec
31 Volunteer Drive
Hendersonville, TN 37075
Telephone 615-824-3634
+1.800.860.6150
Fax +1.615.264.5248
dynatec@itwdynatec.com

JAPAN
ITW Dynatec K.K.
Tsukimura Building 5th Floor
26-11, Nishikamata 7-chome
Ota-ku, Tokyo 144-0051, Japan
Telephone +81.3.5703.5501
Fax +81.3.5703.5505
info@itwdynatec.co.jp

EUROPE, AFRICA and MIDDLE EAST
ITW Dynatec GmbH
Industriestrasse 28
D-40822 Mettmann, Germany
Telephone +49.210.4915.0
Fax +49.210.491.5111
e.mail@itwdynatec.de

Visit us at www.itwdynatec.com