

# Dynamelt™ S Series - Adhesive Supply Unit

DYNAMELT™ S The Dynamelt S system provides accurate, proportionate temperature control for the hopper, hoses, and applicators. Available in four hopper sizes and with a choice of piston or gear pump, the Dynamelt S ASU uses a microprocessor temperature control to accurately control the temperature of hot-melt adhesive for up to six hoses and six heads.

## DYNAMELT™ S Series:

- MELT-ON-DEMAND Hopper Grid extends adhesive life and performance
- 7 year melt-on-demand hopper warranty
- Self-diagnostic P.I. digital Temperature controller with platinum sensor accuracy
- Four hopper sizes fitted with either piston or gear pump
- Hopper grid melts only the adhesive that is demanded by the application, virtually eliminating char.

### Reliability

Melt-On-Demand hopper extends adhesive life and performance.

### Flexibility

Can accommodate up to 6 hoses/heads with either piston or gear pumps.

### Simplicity

Icon-driven control panel simplifies operations.



ITW Dynatec - Dynamelt™ S Series  
Models: S05, S10, S22, S45

480V Transformer Option  
Pendant Control Option

## The Dynatec Difference...

### Melt-on-Demand Hopper

Most suppliers will agree that adhesive degradation is the number one cause of downtime on hot melt equipment. To address this problem, ITW Dynatec has patented a "Melt-On-Demand" system. ITW Dynatec's vertical, unheated hoppers only melt the amount of adhesive required by the application. Most of the hot melt adhesive in the hopper remains at a

much lower temperature, perhaps even solid state. The added benefits of melting only the adhesive required are quicker start-ups, reduced energy costs, better viscosity control, and reduced fumes.

# Dynamelt™ S - Adhesive Supply Unit

System	S05	S10	S22	S45
Hopper Capacity	5k (10lbs)	10k (22lbs)	22k (48lbs)	45k (100lbs)
Operating Temperature	10 to 218°C (50 to 425°F)	10 to 218°C (50 to 425°F)	10 to 218°C (50 to 425°F)	10 to 218°C (50 to 425°F)
Melt Rate (per hour)	10 kg/hr (23lb/hr)	10 kg/hr (23lb/hr)	23 kg/hr (50lb/hr)	23 kg/hr (50lb/hr)
Melt Rate (per hour) - W/ Optional Grid	N/A	19 kg/hr (42lb/hr)	41 kg/hr (90lb/hr)	41 kg/hr (90lb/hr)
Pump Rate (Piston/4.5cc Gear)	.91kg (2 lb)/min/.38kg (.83lb)/min	.91kg (2 lb)/min/.38kg (.83lb)/min	.91kg (2 lb)/min/.38kg (.83lb)/min	.91kg (2 lb)/min/.38kg (.83lb)/min
Piston Pump Compression Ratios	12:1	12:1	12:1	12:1
Gear Pumps Standard	1.5cc/rev, 3.2cc/rev or 4.5cc/rev	1.5cc/rev, 3.2cc/rev or 4.5cc/rev	1.5cc/rev, 3.2cc/rev or 4.5cc/rev	1.5cc/rev, 3.2cc/rev or 4.5cc/rev
Hose Output Zones	2, 4, or 6	2, 4, or 6	2, 4, or 6	2, 4, or 6
Maximum Working Hydraulic Pressure	68 bar (1000psi) - Piston Pump	68 bar (1000psi) - Piston Pump	68 bar (1000psi) - Piston Pump	68 bar (1000psi) - Piston Pump
Temperature Control Stability	± 1°C (1°F)	± 1°C (1°F)	± 1°C (1°F)	± 1°C (1°F)
Electrical Service Standard	240 VAC 1Phase 50/60 Hz	240 VAC 1Phase 50/60 Hz	240 VAC 1Phase 50/60 Hz	240 VAC 1Phase 50/60 Hz
Electrical Service Standard	380 VAC 3Phase Y 50/60 Hz	380 VAC 3Phase Y 50/60 Hz	380 VAC 3Phase Y 50/60 Hz	380 VAC 3Phase Y 50/60 Hz
Working Viscosity	500 to 50,000 cps	500 to 50,000 cps	500 to 50,000 cps	500 to 50,000 cps

\*Melt rates vary with adhesive type. All units capable of 2 hoses and applicators. Units can be fitted with a piston or gear pump.

Dimensions	S05	S10	S22	S45
Height (H)	42 cm (16.5 in) 54.6 cm (21. in)†	61 cm (24 in) 73.6 cm (29 in)†	61 cm (24 in) 73.6 cm (29 in)†	102 cm (40 in) 114.3 cm (45 in)†
Depth (D)	74.5 cm (29.3 in) 83.2 cm (32.7 in)†	74.5 cm (29.3 in) 83.2 cm (32.7 in)†	84 cm (33 in) 83.2 cm (32.7 in)†	84 cm (33 in) 83.2 cm (32.7 in)†
Width (W)	35.5 cm (14 in)	35.5cm (14 in)	35.5cm (14 in)	35.5cm (14 in)
Weight (empty)	43 kg (94lbs)	44 kg (97lbs)	50 kg (110lbs)	54 kg (118lbs)

†Dimensions include the 480 VAC transformer option.

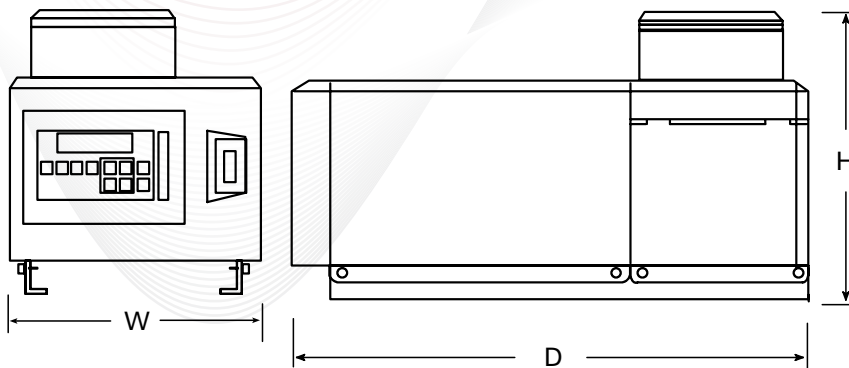

## Optional Accessories

- Analog or digital pressure gauge
- Adhesive level indicator
- Pendant control pattern
- Seven day scheduler
- 480 VAC transformer

## Melt-On-Demand Hopper

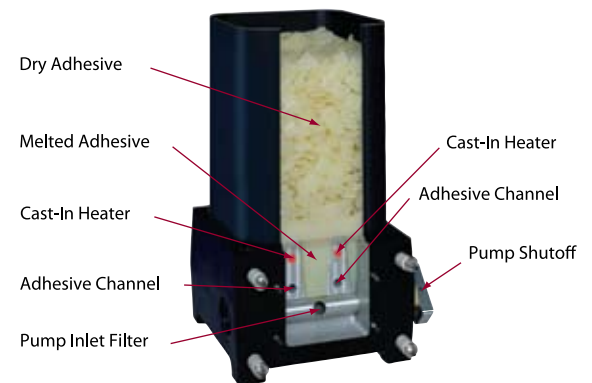

**ITW Dynatec**

**ASIA**  
ITW Dynatec Hong Kong  
Unit A-B, 11/FI., Leahander  
Centre 28  
Wang Wo Tsai Street  
Tsuen Wan NT Hong Kong

**AMERICAS**  
ITW Dynatec  
31 Volunteer Drive  
Hendersonville, TN 37075  
Telephone 615-824-3634  
+1.800.860.6150  
Fax +1.615.264.5248  
dynatec@itwdynatec.com

**JAPAN**  
ITW Dynatec K.K.  
Tsukimura Building 5th Floor  
26-11, Nishikamata 7-chome  
Ota-ku, Tokyo 144-0051, Japan  
Telephone +81.3.5703.5501  
Fax +81.3.5703.5505  
info@itwdynatec.co.jp

**EUROPE, AFRICA and MIDDLE EAST**  
ITW Dynatec GmbH  
Industriestrasse 28  
D-40822 Mettmann, Germany  
Telephone +49.210.4915.0  
Fax +49.210.491.5111  
e.mail@itwdynatec.de

© 8/2008 ITW Dynatec  
ITW Dynatec reserves the right to discontinue or change specifications, designs, materials and equipment without notice or obligation.

Visit us at [www.itwdynatec.com](http://www.itwdynatec.com)