

DG II™ - Hot Melt Hand Applicator

DG II™ - Hot Melt Hand Applicator: The DG II is designed for flexibility connecting to the adhesive supply hose through either a ball swivel fitting or an axial rotation (rotary) fitting. Adhesive output may be oriented for straight or right angle application with a variety of bead and spiral spray nozzles available. The DG II applicator can be fitted for a two- or four-fingered trigger, and set up for bottom-entry or top entry hose connection.

DG II™ - Hot Melt Hand Applicator:

- Rotary or ball swivel with top or bottom hose connection
- Ergonomic handle with a clear sight line to the nozzle tip
- Easy to change cartridge-style heater and sensor
- Two or four finger trigger with built-in trigger lock
- Straight or right angle nozzle adapter
- Bead or swirl applications

Flexibility

Rotary swivel or ball swivel with top or bottom hose connection.

Modular

Can be configured with a two- or four-fingered trigger.

Durability

Rugged and durable glass-filled nylon construction



ITW Dynatec - DG II™ Hand Applicator

The Dynatec Difference...

Flexibility

For applications that require a manual adhesive application, being able to change applications quickly is important. For this reason, ITW Dynatec has designed the DGII manual adhesive applicator to be field-interchangeable with rotary and ball swivel hose connections, as well as top or bottom hose connections. In most cases, the hose connection can

be changed in minutes. This allows more time for production and helps cut downtime due to an application change which, ultimately, saves money.

DG II™ - Hot Melt Hand Applicator

System	DG II
CE Mark	Yes
Temperature Range	38 to 232°C (100 to 450°F)
Maximum Operator Pressure	7 MPa (1,000 psi)
Working Viscosity	0 - 80,000 cps
Flow Rate	.39 kg/min (.9 lb/min)
Voltage / Power Requirements	120 or 240 VAC 50/60 Hz
Solenoid Pressure Range (for swirl application only)	.48 - .96 MPa (70 - 140 psi)
Spray Air Pressure Range (for swirl application only)	0 to .55 MPa (0 to 80 psi)

Dimensions	DG II
Height (H)	22.2 cm (8.74 in)
Depth (D)	22.5 cm (8.46 in)
Width (W)	4.2 cm (1.65 in)
Weight (empty)	.77 kg (1.7 lbs)

Optional Specification / Configurations
<ul style="list-style-type: none"> The ROTARY SWIVEL is useful when the hose is connected at the bottom of the hand applicator. The movement of the applicator can control the hose position. The BALL SWIVEL is useful when the hose is connected at the top of the hand applicator and the applicator is suspended from the hose or a tool balancer. Two- or four-finger trigger configurations available. Right angle bead and swirl nozzle configuration available. Electrical: 80 Watts at 120 or 240 VAC 1 Phase 50/60 Hz

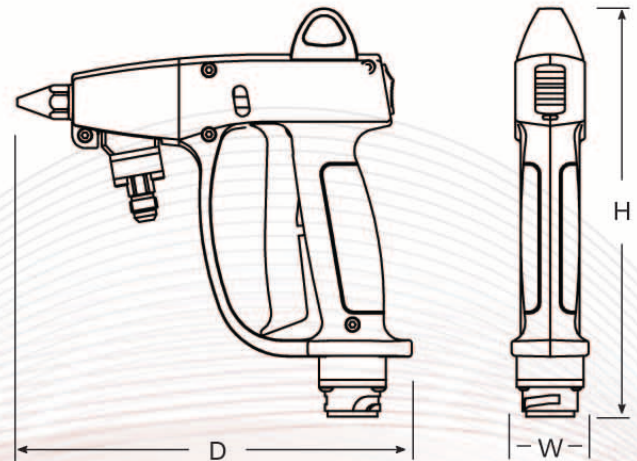

Rotary Swivel (four finger trigger)

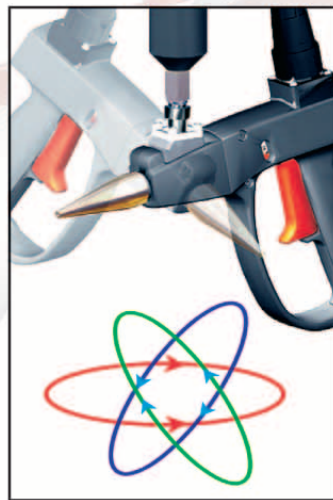

Ball Swivel (two finger trigger)



Right Angle Bead Nozzle



Swirl Spray Nozzle



© 8/2008 ITW Dynatec
ITW Dynatec reserves the right to discontinue or change specifications, designs, materials and equipment without notice or obligation.

hma systems
185 Advance Blvd. Unit 12
Brampton, Ontario.
L6T 4Y3
Tel: 905 458 8182
Fax: 905 458 0758



Adhesive Application Solutions

1800 309 2880

Visit us at - www.hmasystems.com