

Dynamelt™ S Series - Adhesive Supply Unit

The next generation Dynamelt™ S defines a new standard of innovation in the industry. With intuitive controls and a modular design that make it simple to install, operate and maintain, the Dynamelt™ S is the go-to choice for manufacturers worldwide. Unique design and performance features set it apart from the competition, minimizing downtime and offering greater flexibility. Designed to be used in conjunction with the Dynatec family of equipment for maximum efficiency and performance, this virtually “invisible” system will remain in sight but out of mind in your facility.

DYNAMELT™ S Series:

- Simplified access and maintenance procedures make replacing modular electronics, filters and pumps quick and easy.
- Intuitive, easy to read display is repositionable to front or side of unit and shows all system parameters at a glance.
- Consumes up to 20% less energy and significantly less air than similar competitive units, reducing operating costs.
- New Nano ceramic hopper coating is 5 times more durable than competitive PTFE coatings to withstand wear.
- Standard features include 7-Day Scheduler and adhesive level sensor to simplify daily operation.

Flexibility

A compact footprint, ergonomic design, and corner mounted hose connections make this the most versatile, user-friendly melter on the market today.

Reliability

Melt-On-Demand technology, 15 times more filtration area and isolated electronics make this one of the most reliable melters on the market today.

Safety

A lock-out-tag-out main power switch, insulated manifold cover and “finger-safe” electronics maintain safety during both production and maintenance.



ITW Dynatec - Dynamelt™ S Series
Shown: S10 Piston Pump

The Dynatec Difference...

Reduce TCO with the “Invisible” System

To reduce your total cost of ownership, we have not only focused our innovations on reliability, safety and flexibility but on sustainability over the life of the product. The new Dynamelt™ S unit consumes 20% less energy and significantly less air than similar units while advanced diagnostics, quick-change components and a larger filtration surface significantly reduce maintenance cycles and required labor. Combine all of that with

our line of BF applicators, Gemini™ hoses, ADS1™ delivery system, and the EVC-1™ controller that all help to reduce adhesive consumption and additional labor, and you have a superior system for a wide range of packaging applications. Our complete system works “invisible” behind the scenes 24/7 to keep operating costs down and your lines running smoothly.

Dynamelt™ S - Adhesive Supply Unit

System	S05	S10
Hopper Capacity	5kg (10lbs)	10kg (22lbs)
Operating Temperature	10 to 218°C (50 to 425°F)	10 to 218°C (50 to 425°F)
Melt Rate* (per hour)	10 kg/hr (23lb/hr)	10 kg/hr (23lb/hr)
Pump Rate (Piston/4.5cc Gear)	.91kg (2 lb)min/.38kg (.83lb)min	.91kg (2 lb)min/.38kg (.83lb)min
Piston Pump Compression Ratios	12:1	12:1
Gear Pumps Standard	1.5cc/rev, 3.2cc/rev or 4.5cc/rev	1.5cc/rev, 3.2cc/rev or 4.5cc/rev
Air Pressure Supply	0.7 - 6.9 bar (10-100 psi)	0.7 - 6.9 bar (10-100 psi)
Hose Output Zones	2, 4, or 6	2, 4, or 6
Maximum Working Hydraulic Pressure	68 bar (1000psi)	68 bar (1000psi)
Temperature Control Accuracy	± 1°C (1°F)	± 1°C (1°F)
Control Signal Voltage	24 VDC	24 VDC
Electrical Service Standard	240 VAC 1Phase 50/60 Hz 240 VAC 3Phase Δ 50/60 Hz	240 VAC 1Phase 50/60 Hz 240 VAC 3Phase Δ 50/60 Hz
Electrical Service Standard	380 VAC 3Phase Y 50/60 Hz	380 VAC 3Phase Y 50/60 Hz
Working Viscosity	500 to 50,000 cps	500 to 50,000 cps

*Melt rates vary with adhesive type. Units can be fitted with a piston or gear pump.

Dimensions	S05	S10
Height (H)†	53.23 cm (20.96 in)	66.04 cm (26 in)
Depth (D)	42.67 cm (16.8 in)	42.67 cm (16.8 in)
Width (W)	65.5 cm (25.79 in)	65.5 cm (25.79 in)
Weight (empty)	59 kg (129 lbs)	63 kg (138 lbs)

†The 480 VAC transformer option adds 12.7 cm (5 in.) to height

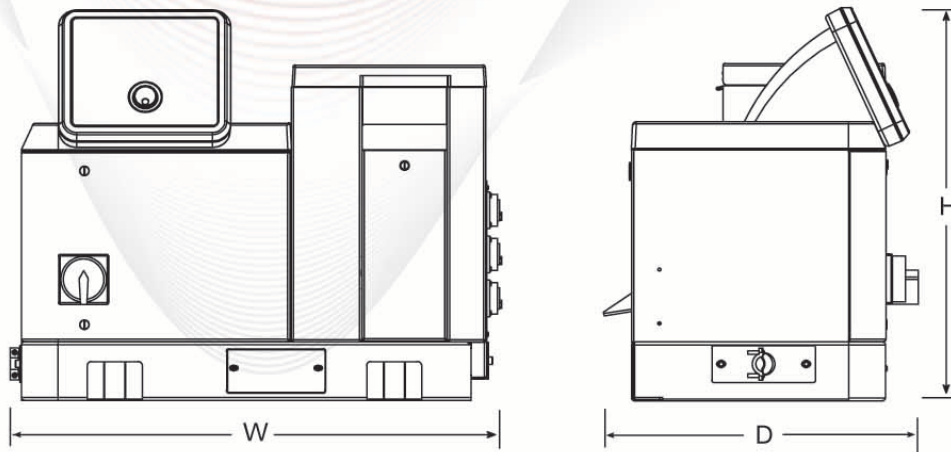

Ergonomic Design & Simplified Access

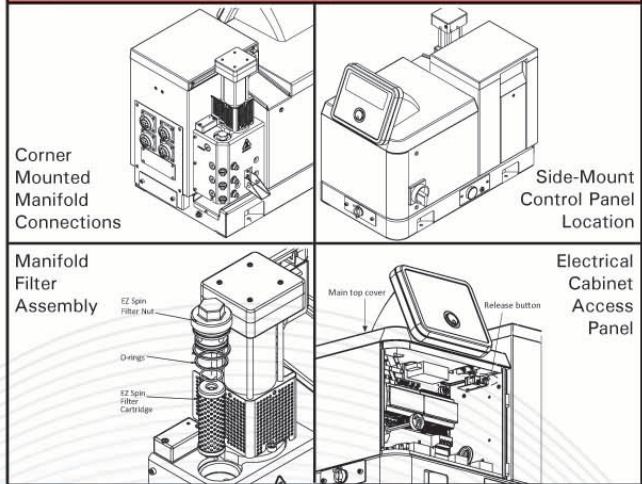

Optional Accessories

- Analog or digital pressure gauge
- Tethered pendant controller display
- 480 VAC transformer
- Stack light status indicator
- Ethernet module

Patented Melt-On-Demand Hopper Technology

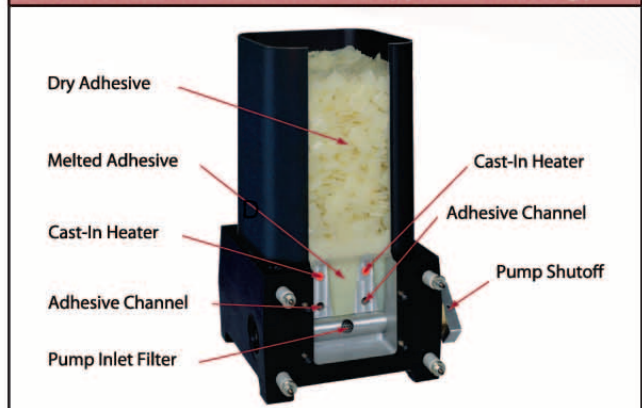

Patented Melt-On-Demand Technology heats from the bottom up, melting only the adhesive needed to prevent charring and degradation. The added benefits of melting only the adhesive required are quicker start-ups, reduced energy costs, better viscosity control, and reduced fumes.



hma systems
 185 Advance Blvd. Unit 12
 Brampton, Ontario.
 L6T 4Y3
 Tel: 905 458 8182
 Fax: 905 458 0758



Adhesive Application Solutions